



STC557 SERIES

NYLON SPLIT GROMMETS



Conforms to: NAS 557

Step'n Components, Nylon Split Grommets are molded from nylon to offer easy installation in round holes, hole sizes of 3/16" to 3" diameter and bulkhead material thicknesses (.025 – .125).

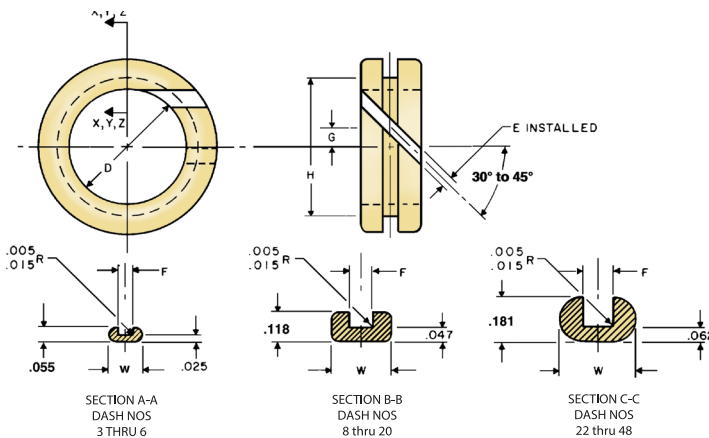

MATERIAL:

Nylon 6/6 per ASTM D4066 (PA 0111)
(For applications to 275°F)

COLORS: Natural

CODE:

Part number designates grommet size as indicated in Table 1.
Dash number must be suffixed by sheet thickness designation as indicated in Table II.

EXAMPLE:

STC 557-8A
Split plastic grommet having .188 installed I.D. for installation in a .594 hole in .025 to .051 sheet.



17832 Gothard Street
Huntington Beach, CA 92647

P: 714-362-3713
F: 714-362-3714

www.stepnco.com



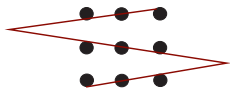

Step'n Components

NAS557

SPLIT GROMMETS

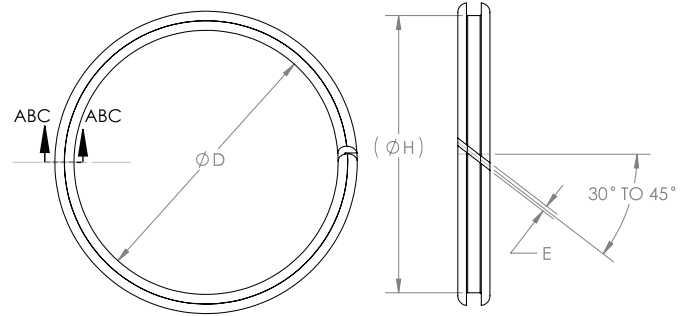
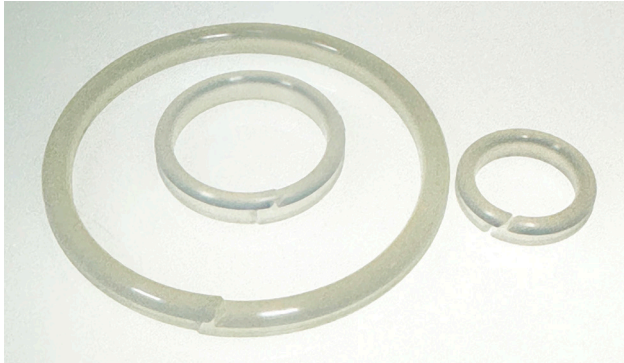

Dash Number	Ø D INSTALLED	E MAX INSTALLED	Ø H	SECTION
3	.188	.030	.241	A-A
4	.250		.303	
6	.375		.429	
8	.500	.47	.601	B-B
10	.625		.726	
12	.750		.851	
14	.875		.976	
16	1.000		1.101	
18	1.125		1.226	
20	1.250		1.351	
22	1.375	.062	1.507	C-C
24	1.500		1.632	
28	1.750		1.882	
32	2.000		2.132	
36	2.250		2.382	
40	2.500		2.632	
44	2.750		2.882	
46	2.875		3.007	
48	3.000	3.132		

Material:
Nylon 6/6 PER
ASTM D4066, PA0111

Color:
Natural

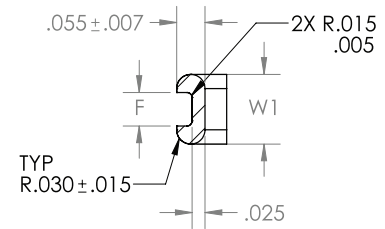

SECTION A-A
SCALE 4 : 1

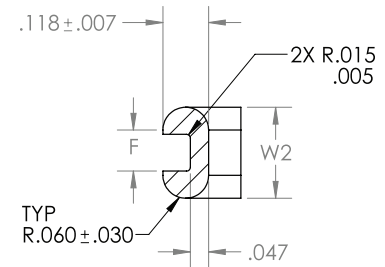

SECTION B-B
SCALE 3 : 1

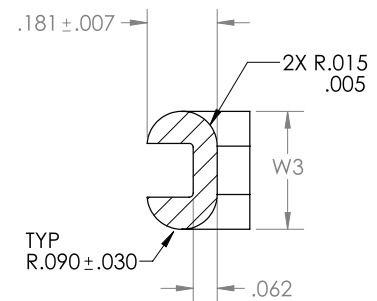

SECTION C-C
SCALE 3 : 1

TYPE	F	W1	W2	W3
A	.070 .060	.135	.210	.230
B	.100 .090	.155	.235	.260
C	.144 .134	.179	.245	.305

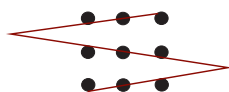

Step'n Components

17832 Gothard Street | Huntington Beach, CA 92647 | Phone: 714-362-3713
Fax: 714-362-3714 | Email: sales@stepnco.com | www.stepnco.com

